

ALKALINE-MANGANESE DIOXIDE BATTERY

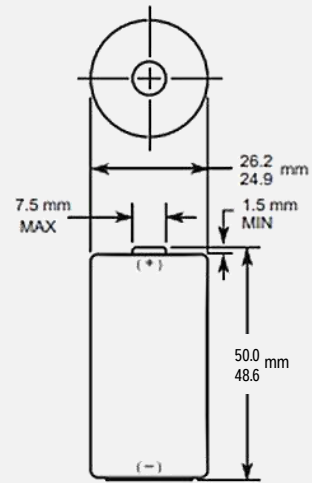

Size: C (LR14) PX1400



Dimensions shown are IEC standards

KEY FEATURES

- Reliable Performance
- Excellent resistance to corrosion
- Designed to meet all major quality, safety and environmental standards:
 - Safety: IEC 60086-5
 - ANSI C 18.1M, Part-2
 - EU Battery Directive
 - Quality: ISO 14001 and 9001, Duracell World Class Continuous Improvement Program

TYPICAL APPLICATIONS

- Sanitizer Dispensers
- Air Fresheners
- Paper Towel Dispensers
- Flashlights
- Soap Dispensers

ELECTRICAL CHARACTERISTICS

- Nominal capacity (25 mA Cont., .8V cut-off) 8,240 mAh
- Typical Voltage (at + 20 °C) 1.5 V
- AC Impedance @ 1kHz 74 mΩ

PHYSICAL CHARACTERISTICS

- Typical weight 65.0 g (2.5 oz)
- Typical volume 26.9 cm³ (1.6 in³)
- Terminals Flat

OPERATING & STORAGE CONDITIONS

- Operating temperature range -20°C to 54°C (-4°F to 130°F)
- Recommended Storage (storage area should be clean, cool, dry and ventilated) 5°C to 30°C (41°F to 86°F)

TYPICAL PERFORMANCE

Constant Current

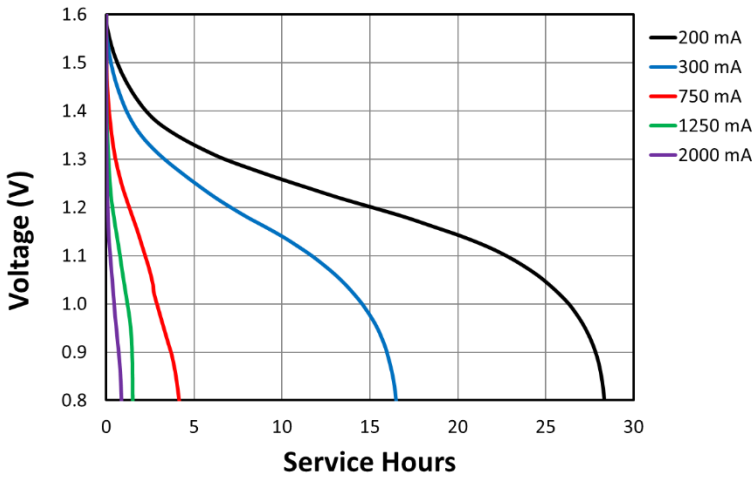

Constant Resistance

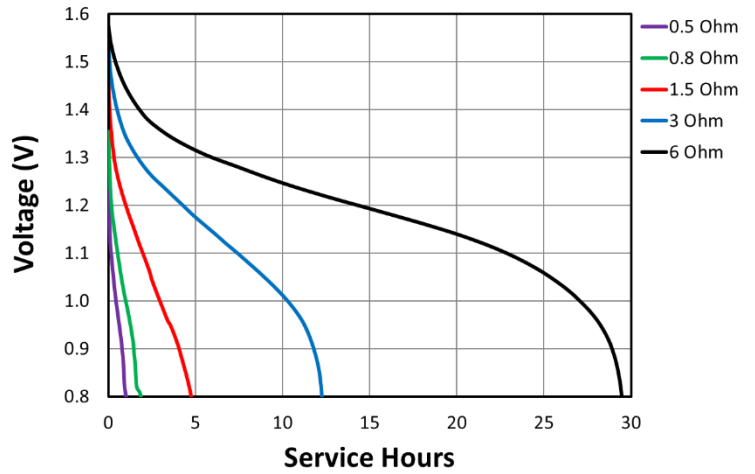

Constant Power

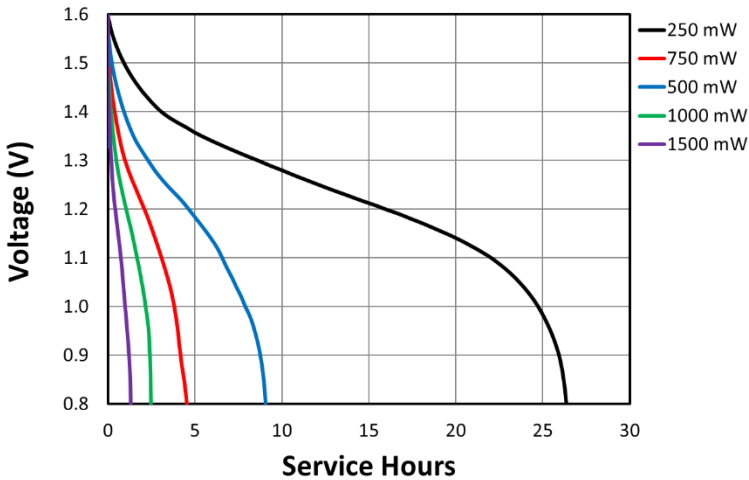

Constant Current - 200 mA

