

Primary lithium battery

LSH 14

3.6 V Primary lithium-thionyl chloride (Li-SOCl₂)

High power

C-size spiral cell



Benefits

- High voltage response, stable during most of the lifetime of the application
- High drain/pulse capability
- Wide operating temperature range (-60°C/85°C)
- Easy integration in compact system
- Low self-discharge rate (less than 3 % after 1 year of storage at +20°C)

Key features

- Stainless steel container
- Hermetic glass-to-metal sealing
- Built-in safety vent
- Finish with 5 A fuse
- Non-flammable electrolyte
- Underwriters Laboratories (UL) Component Recognition (File Number MH 12609)
- Compliant with IEC 60086-4
- Restricted for transport (Class 9)

Main applications

- Radiocommunication and other military applications
- Alarms and security systems
- Beacons and emergency location transmitters
- GPS
- Metering systems
- Sonobuoys
- Automotive telematics
- Pipeline inspection

NATO stock number
6135 12 306 4125

Cell size references

UM2 - R14 - C

Electrical characteristics

(typical values relative to cells stored for one year or less at +30°C max.)

Nominal capacity (at 15 mA + 20°C 2.0 V cut-off. The capacity restored by the cell varies according to current drain, temperature and cut-off)	5.8 Ah
Open circuit voltage (at +20°C)	3.67 V
Nominal voltage (at 1mA + 20°C)	3.6 V

Pulse capability: Typically up to 2000 mA (2000 mA/0.1 second pulses, drained every 2 mn at +20°C from undischarged cells with 10 µA base current, yield voltage readings above 3.0 V. The readings may vary according to the pulse characteristics, the temperature, and the cell's previous history. Fitting the cell with a capacitor may be recommended in severe conditions. Consult Saft)

Maximum recommended continuous current (to maintain cell heating within safe limits. Battery packs may imply lower level of maximum current and may request specific thermal protection. Consult Saft)	1300 mA
---	---------

Storage (recommended) (for more severe conditions, consult Saft)	+ 30°C (+ 86°F) max
---	---------------------

Operating temperature range (Operation at extreme T may lead to reduced capacity and lower voltage readings at the beginning of pulses. Consult Saft)	- 60°C/+ 85°C (- 76°F/+ 185°F)
--	-----------------------------------

Physical characteristics

Diameter (max)	26.0 mm (1.02 in)
Height (max)	50.4 mm (1.98 in)
Typical weight	51 g (1.8 oz)
Li metal content	approx. 1.7 g

Available termination suffix

CN, CNR	radial tabs
3PF, 3 PF RP	radial pins
CNA (AX)	axial leads
FL	flying leads ...etc.



LSH 14

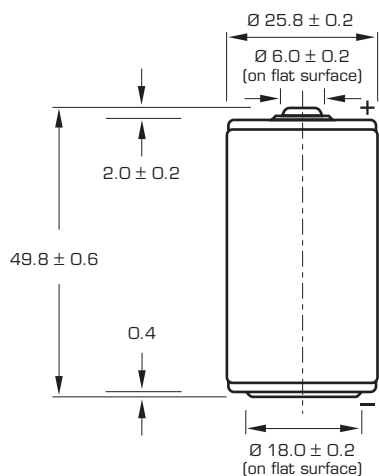

Dimensions in mm.

Storage

- The storage area should be clean, cool (preferably not exceeding +30°C), dry and ventilated.

Warning

- Fire, explosion and burn hazard.
- Do not recharge, short circuit, crush, disassemble, heat above 100°C (212°F), incinerate, or expose contents to water.
- Do not solder directly to the cell (use tabbed cell versions instead).

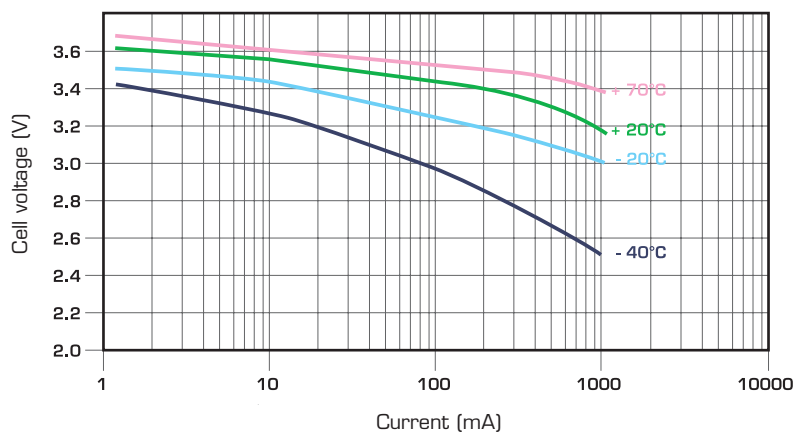

Voltage plateau versus Current and Temperature (at mid-discharge)

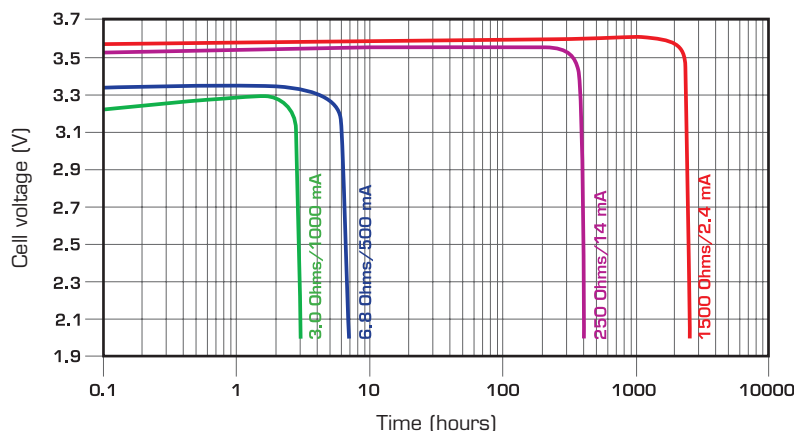

Typical discharge profiles at +20°C

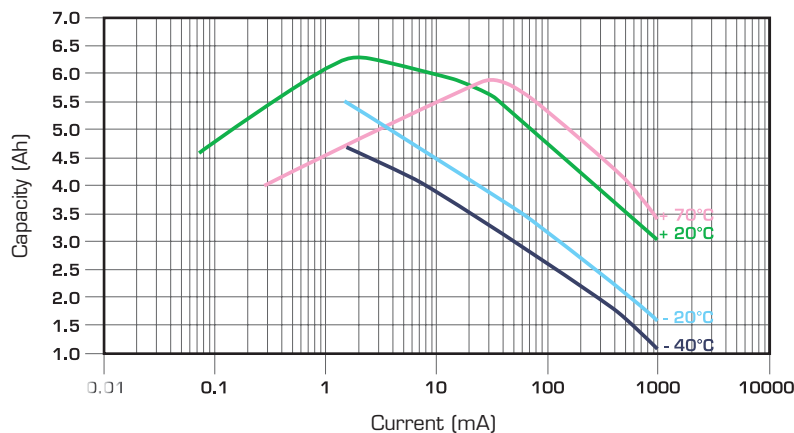

Restored Capacity versus Current and Temperature (2.0 V cut-off)

CELL PACK
SOLUTIONS

Telephone: +44 (0)191 496 9999

Email: batteries@cellpacksolutions.co.uk

Website: www.cellpacksolutions.co.uk

Doc. N° 31013-2-0607

Information in this document is subject to change without notice and becomes contractual only after written confirmation by Saft.

For more details on primary lithium technologies please refer to Primary Lithium Batteries Selector Guide Doc N° 31048-2.

Published by the Communications Department.

Photo credit: Saft

Société anonyme au capital de 31 944 000 €
RCS Bobigny B 383 703 873

Produced by Arthur Associates

