

Top

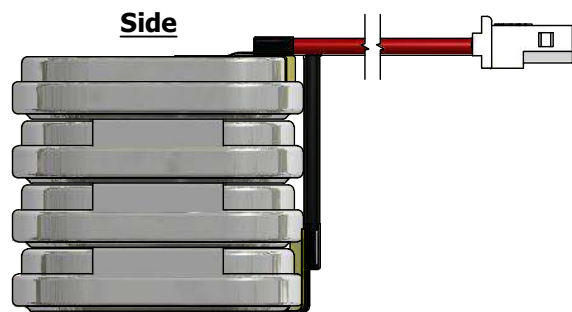

Side

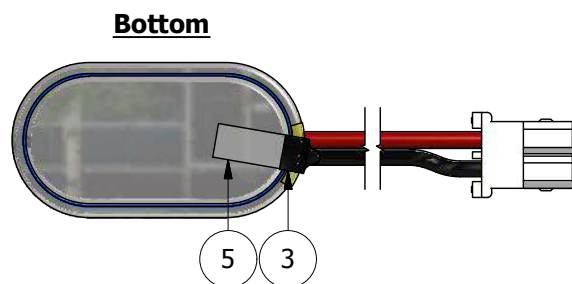

Bottom

PARTS LIST			
ITEM	QTY	PART NUMBER	DESCRIPTION
1	1	CON 065 H	Molex 2-Way Housing (50-37-5023)
2	2	Insulation Tape	Insulation Tape
3	2	PF2X24-10	Shrink Sleeve 2.4mm ID x 10mm Long
4	1	TAG002-10	MS STRIP (3mm x 0.1) x 10mm Long
5	1	TAG002-20	MS STRIP (3mm x 0.1) x 20mm Long
6	4	V150H	1.2v 150mA NiMH (NO PINS)
7	1	WIR004-110	WIRE 16/0.2 T2 DEF61-12 PT6 PVC BLACK x 110mm Long 6003158
8	1	WIR005-95	WIRE 16 x 0.2 RED x 95mm Long
9	3	Weld Cap	WELD CAP

Isometric (2 : 1)

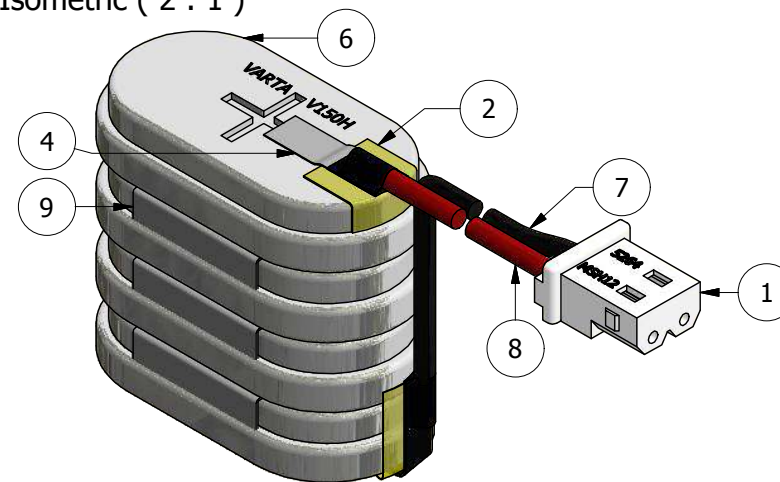

Please Note:

- i) All solder joints to be sleeved (3).
- ii) Pack to be sleeved both ways (&).

Additional Information

Voltage: 4.8V
Capacity: 150mAh
Format: 4B
Chemistry: NIMH

Cell Pack Solutions Ltd further reserves all rights (including all rights of manufacture) relating to this drawing. The use of this drawing is restricted to those uses for which it was specifically made.

Dimensioned in mm		Cell Pack Solutions Ltd.	
Drawn By:	RussB	Scale :	1.5:1
Checked By:		measurement tolerance	Projection
Revision:	Date:	to ± 0.1	
1	13/08/2012	CPS 1313 A	

CELL PACK SOLUTIONS

Telephone: +44 (0)191 496 9999
 Email: batteries@cellpacksolutions.co.uk
 Website: www.cellpacksolutions.co.uk