

Model No.: **GP400LAHT**

Type	: High Temperature Rechargeable Nickel Metal Hydride Cylindrical Cell
IEC Designation	: T
Nominal Dimension (with Sleeve)	: $\Phi = 18.3\text{mm}$ H = 70.0mm
Applications	: Long term standby use. Recommended discharge current: 400mA to 2000mA
Nominal Voltage	: 1.2V
Capacity	: Rated: 4000mAh Typical: 4120mAh When discharged at 800mA to 1.0V at 20°C
Charging Condition	: Standard mode: 400mA for 16 hrs at 20°C Standby intermittent mode: 400mA for 16 hrs at 20°C then maintenance with 400mA for 1min/10mins.
Charging Retention	: 80% of rated capacity after cell storage at 20°C for 12 months When discharged at 800mA to 1.0V at 20°C
Service Life	: >500 cycles (IEC standard)
Continuous Overcharge	: Comply with IEC standard Permanent Charge Endurance Test
Weight	: 67.0g
Internal Resistance	: Average 17 m Ω upon fully charged (Max. 25m Ω) at 1000Hz
Max. Charging Voltage	: 1.6V at 400mA charging
Ambient Temperature Range	: *Charge: 0 to 70°C *Discharging: -20 to 70°C Storage: -20 to 35°C Storage (1 week): -20 to 60°C

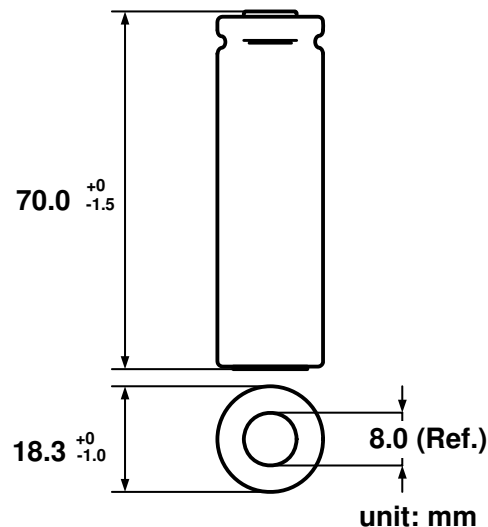

Low Rate Discharge

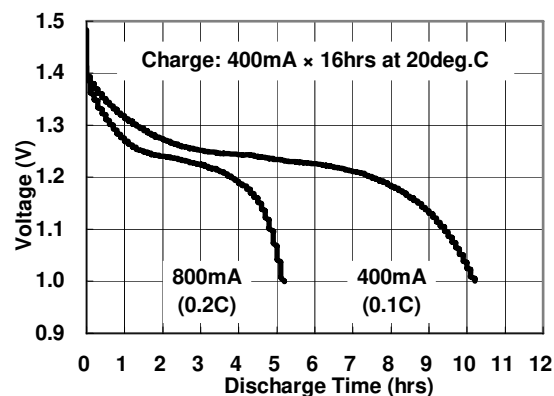

High Rate Discharge

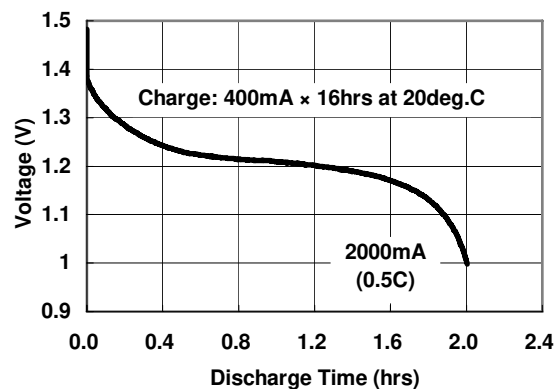

* Charge/discharge temperature range: 55~70°C shorter than 1 month

Charge & Discharge efficiency Vs. temp.

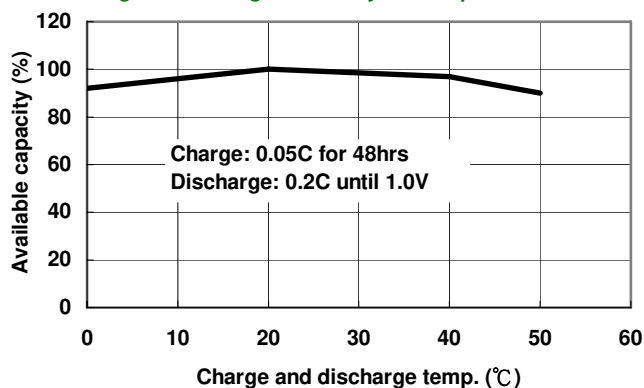

The information (subject to change without prior notice) contained in this document is for reference only and should not be used as a basis for product guarantee or warranty. For applications other than those described here, please consult your nearest GP Sales and Marketing Office or Distributors.